

Item # \_\_\_\_\_

Quantity \_\_\_\_\_

# Enclosed Tray Trucks

## Elite Series™ High Capacity - Stainless Steel



Model 5628



### Designed For Delivery Of Insulated Meal Trays.

- Accommodates 14" x 18" or 15" x 20" size trays, two per ledge.
- Doors open 270° for unobstructed access.
- Paddle latch door catch assures positive door closure and convenient one-hand opening.
- Sturdy welded tubular push handle for increased maneuverability.
- Cart body and removable stainless steel ledge panels are easily cleaned and sanitized.
- Base corner bumpers protect walls, furnishings and doors.
- Compartment floor drains facilitate interior cleaning.
- Increased capacity and visibility during transport.

Spec. # \_\_\_\_\_



Removable Ledge Panels

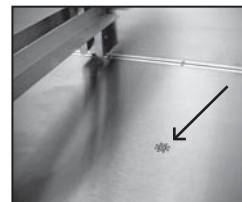

Compartment Floor Drain



Two Trays Per Ledge

AIA # \_\_\_\_\_

### Specifications

Unit shall be of Type 304 stainless steel welded and riveted construction to accommodate 14" x 18" (356 x 457 mm) or 15" x 20" (381 x 508 mm) trays. Material thickness shall be of 16 gauge for top and floor/base, 20 gauge for sides and back. Doors shall be of 20 gauge insulated double-pan design, and shall be mounted to unit frame with two each 3" (76 mm) heavy-duty stainless steel hinges. Hinges shall be welded to door and unit frame. Doors shall swing 270° to provide full access to tray compartments, and shall be easily removable by lifting off of hinges. Door latches shall be recessed paddle design. Tray ledges shall be 18 gauge stainless steel angle, welded to an 18 gauge stainless steel frame panel at 5¼" (133 mm) spacing. Ledge panels shall be shall accommodate both 14" x 18" or 15" x 20" trays (two trays per ledge), and shall be removable for easy cleaning. Tray compartments shall have vents on end panels and shall have perforated center floor drains. Unit base shall have 1¼" (32 mm) thick extruded PVC rounded bumpers mounted to corners. A 1" tubular push handle shall be welded to one end of the unit. Unit shall have four each extra-load plate type casters, two fixed and two swivel, mounted to a 14 gauge stainless steel dolly on unit base. Swivel casters shall have shielded ball bearing races and zerk fillings for lubrication of bearings. Caster wheels shall be 6" (152 mm) diameter with 2" wide, non-marking, rounded cushion tread. Unit shall be NSF listed.



Lakeside Manufacturing, Inc.  
 4900 West Electric Avenue • West Milwaukee, WI 53219 U.S.A.  
 800-558-8565 • 414-902-6400 • Fax 414-902-6446 • www.eLakeside.com

# Enclosed Tray Trucks

## Elite Series™ High Capacity - Stainless Steel

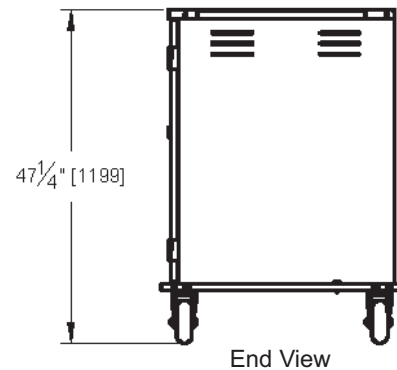
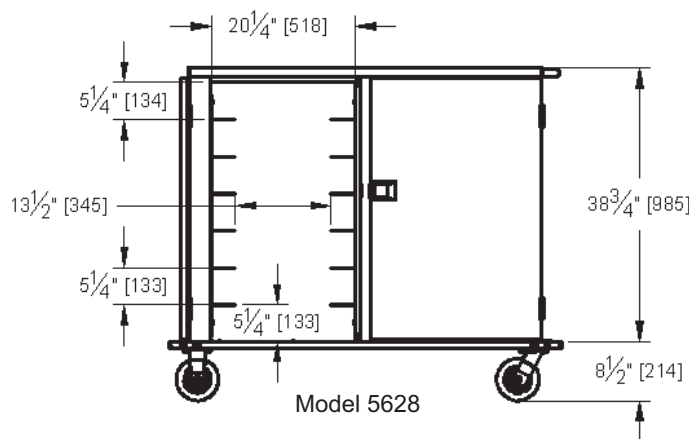
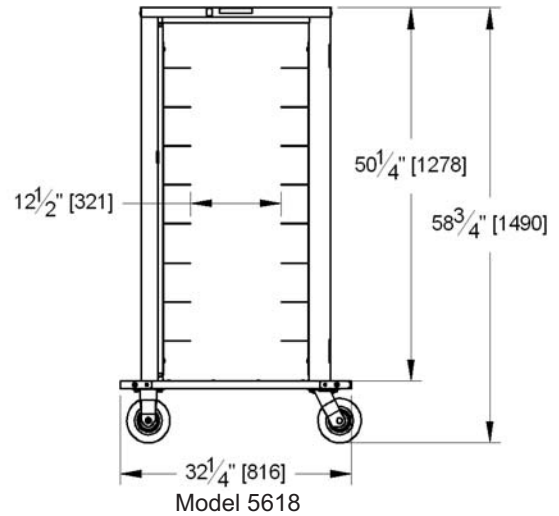
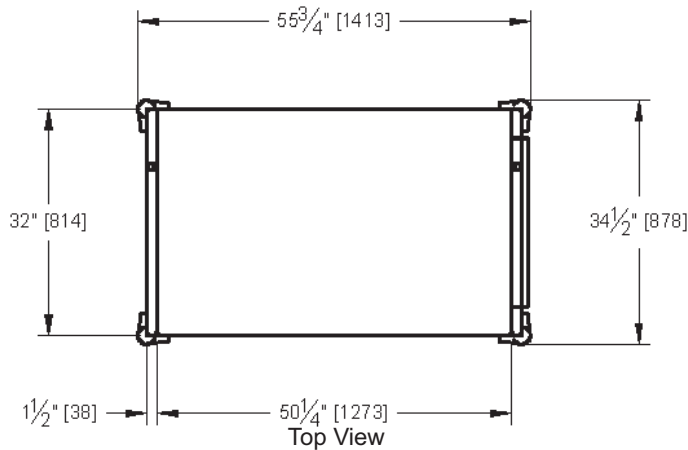

### Dimensions

Model	Tray Capacity	Ledge Spacing	Compartments/Trays Per Ledge	Overall Size			Lake-Glide Casters		Ship Weight	
				W	D	H	Type	Dia.	Lbs	(Kg)
5618	18	5 1/4" (133)	1/2	33" (838)	36 3/4" (933)	58 3/4" (1492)	2 Fixed 2 Swivel	6" (152)	198	(90)
5620	20	5 1/4" (133)	1/2	33" (838)	36 3/4" (933)	64" (1626)	2 Fixed 2 Swivel	6" (152)	218	(99)
5624	24	5 1/4" (133)	2/2	55 3/4" (1416)	34 1/2" (876)	42" (1067)	2 Fixed 2 Swivel	6" (152)	305	(139)
5628	28	5 1/4" (133)	2/2	55 3/4" (1416)	34 1/2" (876)	47 3/4" (1213)	2 fixed 2 Swivel	6" (152)	335	(152)
5632	32	5 1/4" (133)	2/2	55 3/4" (1416)	34 1/2" (876)	52 1/2" (1334)	2 fixed 2 Swivel	6" (152)	365	(166)

Measurements in ( ) denote metric millimeters, unless otherwise specified.

### Optional Accessories

- Custom ledge spacing
- Transport door latch
- Full perimeter bumper
- 8" casters
- 2" top rail (3 sides)
- 6 each 6" casters (4 swivel, 2 fixed)
- Creased compartment floor (for drain)
- Menu card holder
- Towing hitch



Lakeside Manufacturing, Inc.  
4900 West Electric Avenue • West Milwaukee, WI 53219 U.S.A.  
800-558-8565 • 414-902-6400 • Fax 414-902-6446 • www.eLakeside.com