

Compact Mart Cart

Mobile Kiosk

Item # _____

Quantity _____



Model 660

Mart Cart is Ideal for High Traffic Areas Where People Congregate.

- Multi-use interior with pull out stainless steel shelf.
- Interior shelf is height adjustable and removable.
- Stainless steel overshelf puts products at your fingertips. Shelf tilts toward the operator for easy access. Overshelf accepts standard size insert pans, and is height adjustable.
- Cart is lightweight and easy to maneuver with tough-duty 5" swivel casters and ergonomic vertical handles.
- Sized for maneuvering into elevators, down corridors and into kitchen areas.
- Optional merchandising front and/or overshelf panels.
- Easy to clean and sanitize stainless steel work surface top and interior.
- Eight attractive and durable laminate exterior finishes are standard. Custom laminate finishes can be ordered to match existing decor.

Spec. # _____

AIA # _____



Front view show with optional merchandising panels.



Back View



Lakeside Manufacturing, Inc.
 4900 West Electric Avenue • West Milwaukee, WI 53219 U.S.A.
 800-558-8565 • 414-902-6400 • Fax 414-902-6446 • www.eLakeside.com

Compact Mart Cart

Mobile Kiosk

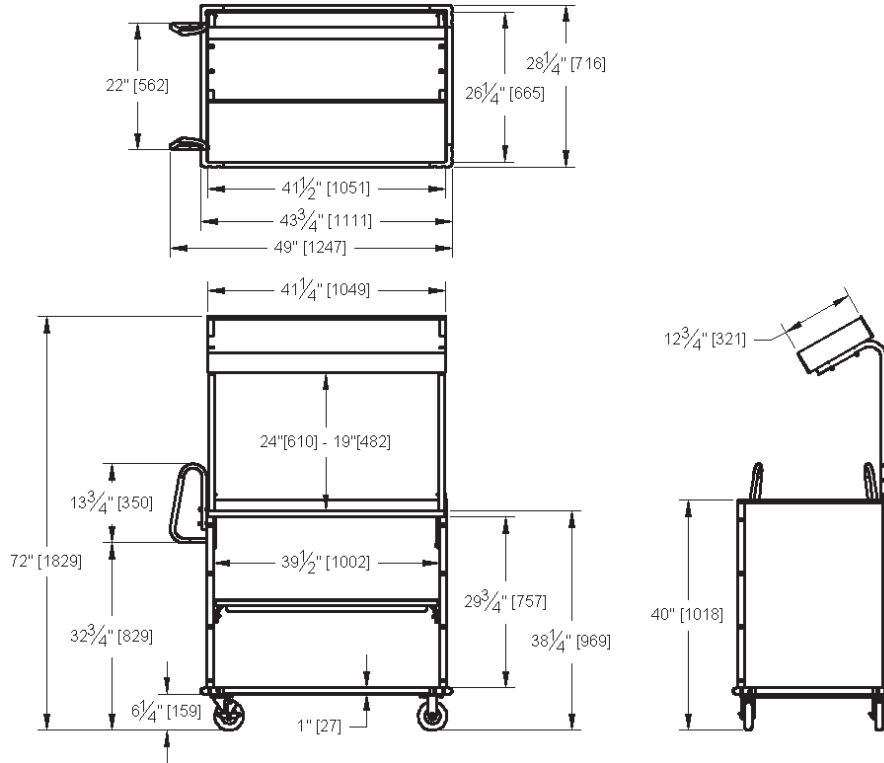

Spec. #

AIA #

Dimensions: Overall dimensions: 28 1/4" W x 49" L x 72" H (692 W x 1245 L x 1829 mm)
 Interior compartment: 39 1/2" W x 26" D x 30" H (1002 W x 660 D x 762 mm)
 Height to countertop from floor: 38 1/4" (969 mm)
 Height from countertop to bottom of overshelf: 19" - 24" (482 - 610 mm)
 Pull Out Shelf: 38 1/2" W x 25" D (978 W x 635 D)

Specifications: Model #660 shall include a stainless steel overshelf measuring 12 3/4" W x 41 1/4" L x 3 3/4" D (321 W x 1049 L x 95 D mm) as standard. Overshelf shall accept standard size insert pans, and shall be suspended on two each 7/8" (22 mm) diameter tubular stainless steel supports. Support height shall be adjustable, providing a 5" (127 mm) overshelf adjustable height range. Handles shall be vertical ergonomic design with vinyl grips measuring 8-1/2" H (216 mm). Interior compartment shall have a slide out, removable and adjustable stainless steel shelf with heavy duty drawer slides. Slide out shelf shall have a load capacity of 70 pounds. Top work surface shall be 26 1/4" W x 41 1/4" L (665 W x 1049 L mm). The cart interior shall be 20 gauge stainless steel and shall have a drain hole in the bottom to facilitate cleaning. The cart exterior sides shall be vertical grade laminate over stainless steel, with plastic corner edge molding. Cart shall have bottom perimeter bumper. Cart shall have 2 each swivel, 2 each fixed casters (2 each with brakes). Casters shall have 5" (127 mm) rounded cushion tread non-marking wheels.

- Optional Accessories:**
- Cup dispenser
 - Merchandising panels for front and overshelf



Lakeside Manufacturing, Inc.
 4900 West Electric Avenue • West Milwaukee, WI 53219 U.S.A.
 800-558-8565 • 414-902-6400 • Fax 414-902-6446 • www.eLakeside.com